

For detailed datsheets please contact ELPACTO

# ELPACTO

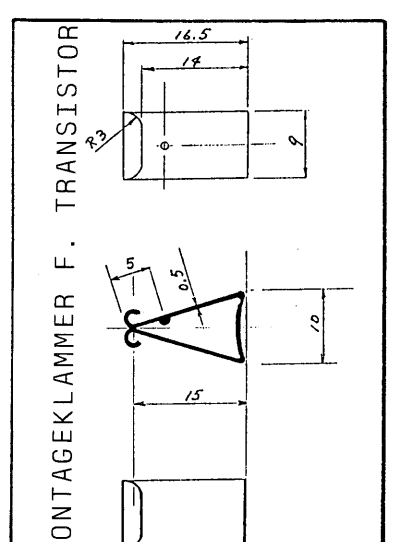

# ELPACTO

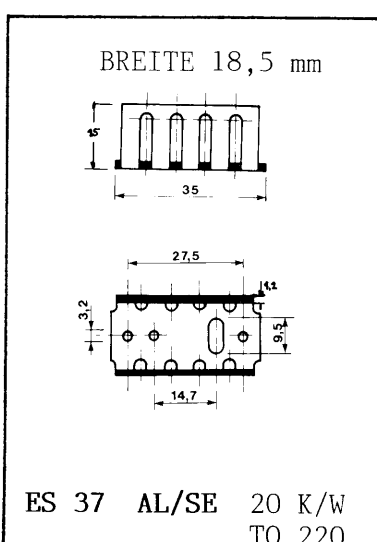
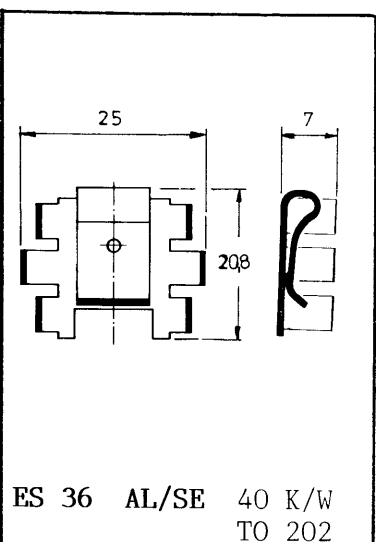
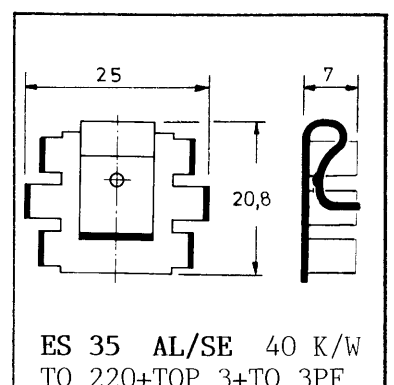
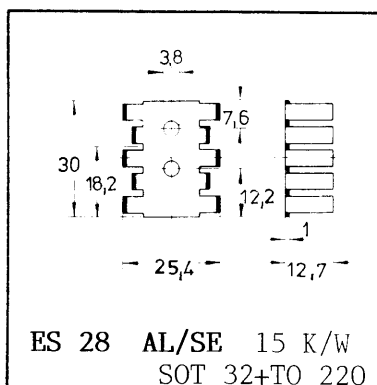
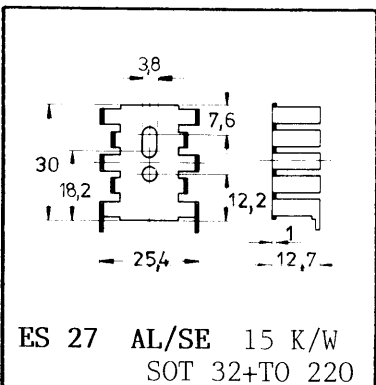
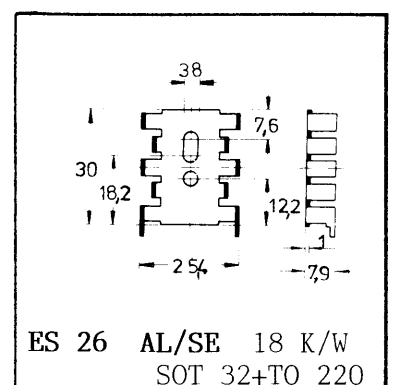
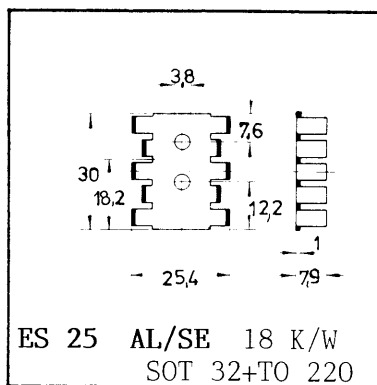
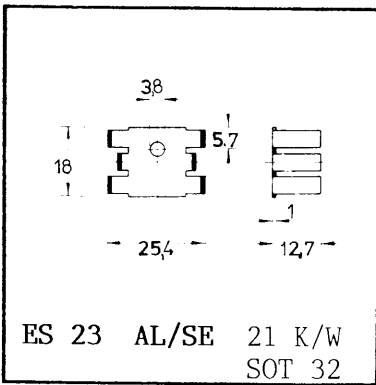
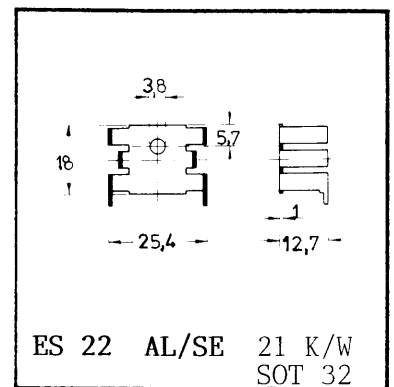
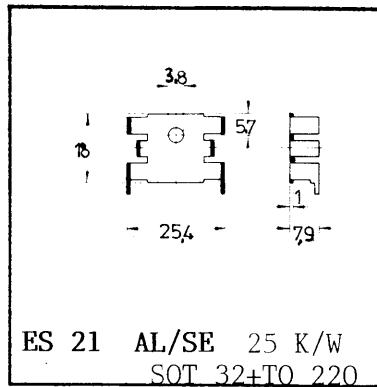
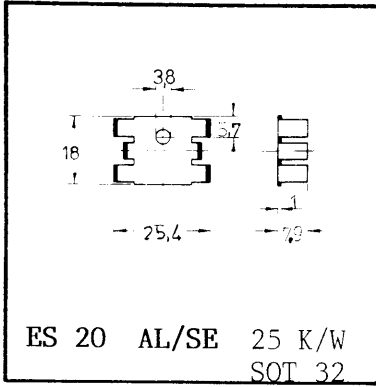
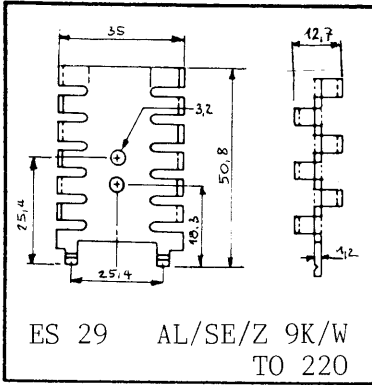

ES 29 AL/SE/Z 9K/W  
TO 220

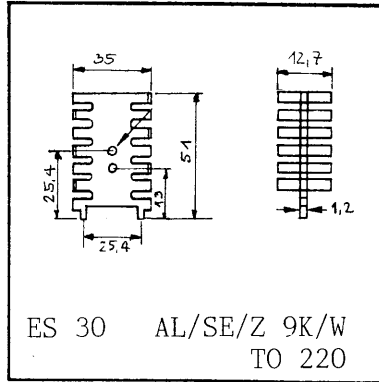

ES 30 AL/SE/Z 9K/W  
TO 220

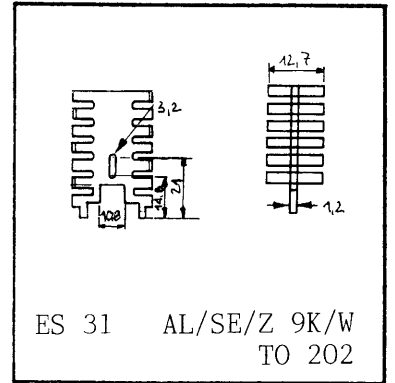

ES 31 AL/SE/Z 9K/W  
TO 202

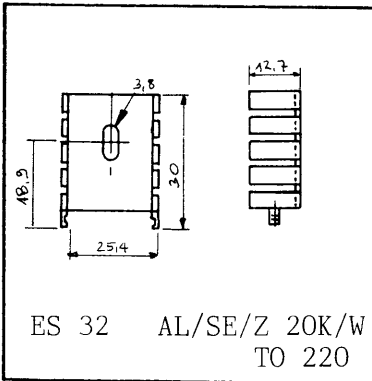

ES 32 AL/SE/Z 20K/W  
TO 220

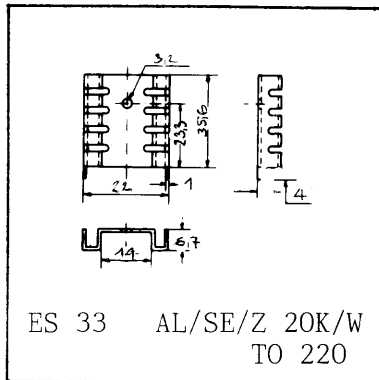

ES 33 AL/SE/Z 20K/W  
TO 220

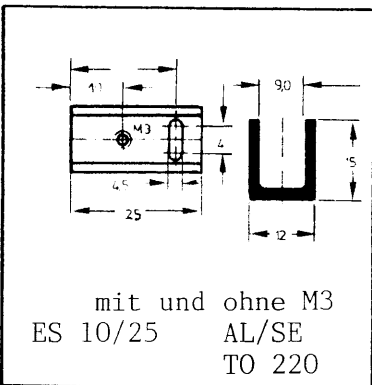
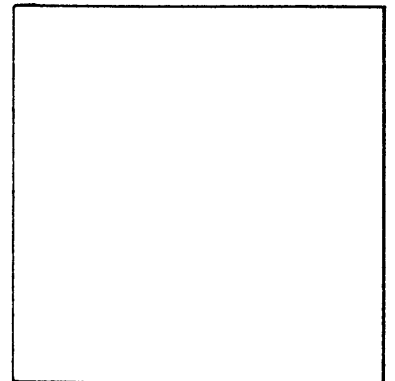

mit und ohne M3  
ES 10/25 AL/SE  
TO 220

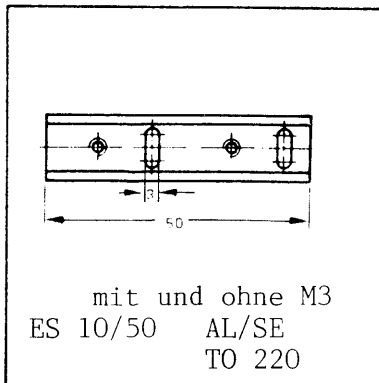

mit und ohne M3  
ES 10/50 AL/SE  
TO 220

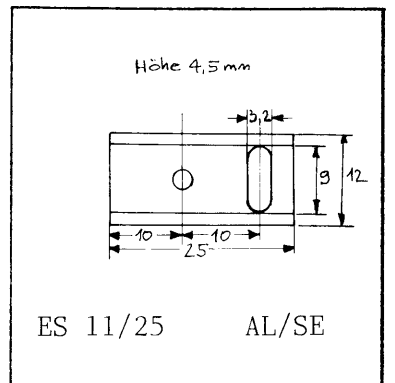

ES 11/25 AL/SE

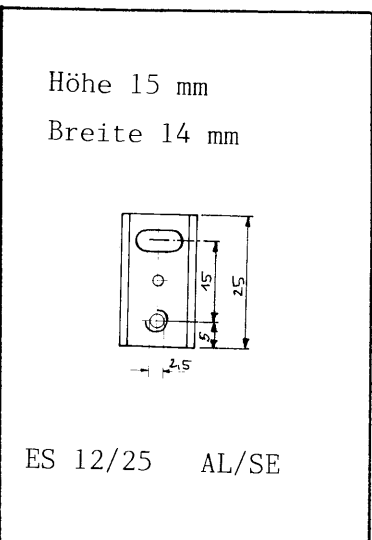

Höhe 15 mm  
Breite 14 mm

ES 12/25 AL/SE

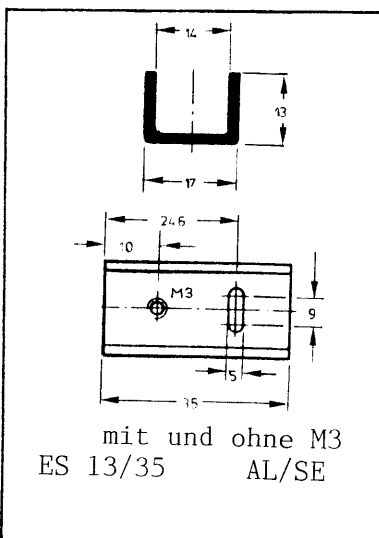

mit und ohne M3  
ES 13/35 AL/SE

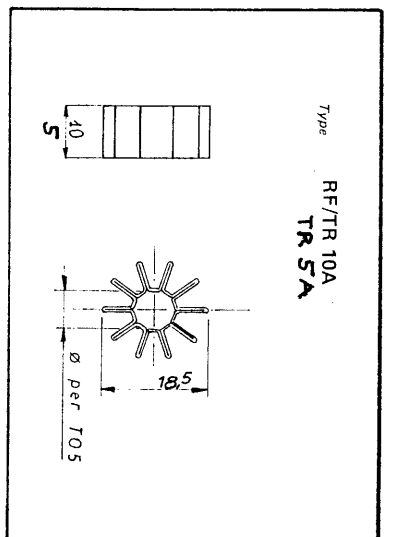

Type  
RF/TR 10A  
TR SA

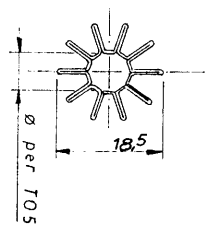

# ELPACTO

Type	Profil	Wärmewiderstand C/W					für Gehäuse Bemerkungen
		matt schwarz eloxiert					
		37.5	50	75	100		
EP 042							
EP 050							
EP 055							
EP 164							
EP 169							
EP 170							

## Thermal Performance Correction Graphs

Heatsink thermal performance was evaluated using vertical anodised heatsinks, 150mm long, in natural convection ( $R_{th,n}$ ) and in forced convection ( $R_{th,f}$ ) at 2m/s airflow. Evaluation was conducted with a distributed load and a 70°C temperature rise.

The following curves can be used to calculate the thermal resistance of a heatsink at a different length and/or with different speeds of forced ventilation.

ALL THE REPORTED VALUES ARE INDICATIVE ONLY. THE THERMAL RESISTANCE OF A HEATSINK MUST BE EVALUATED UNDER ACTUAL OPERATING CONDITIONS.

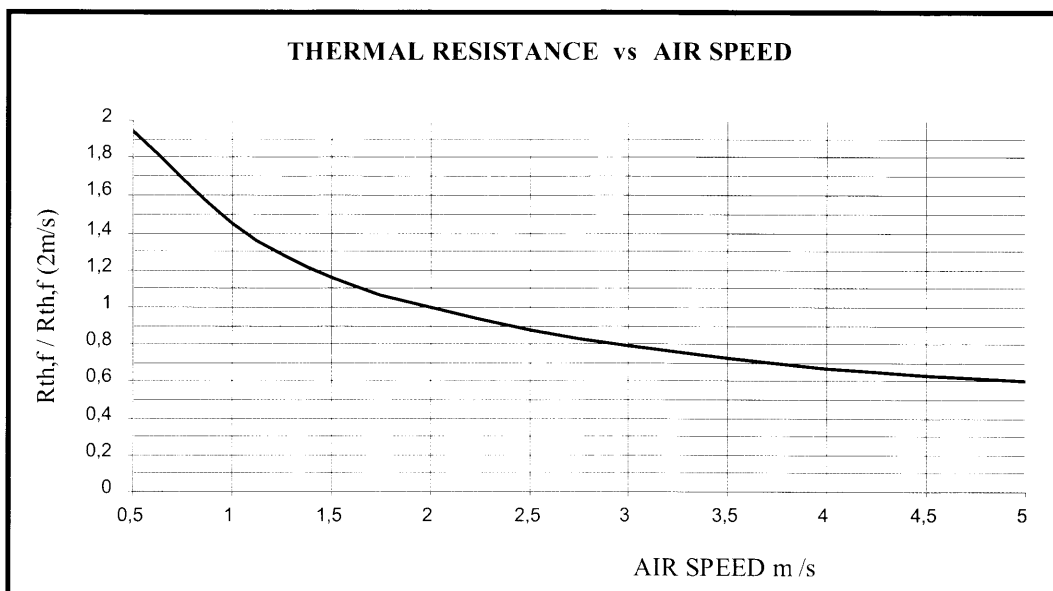
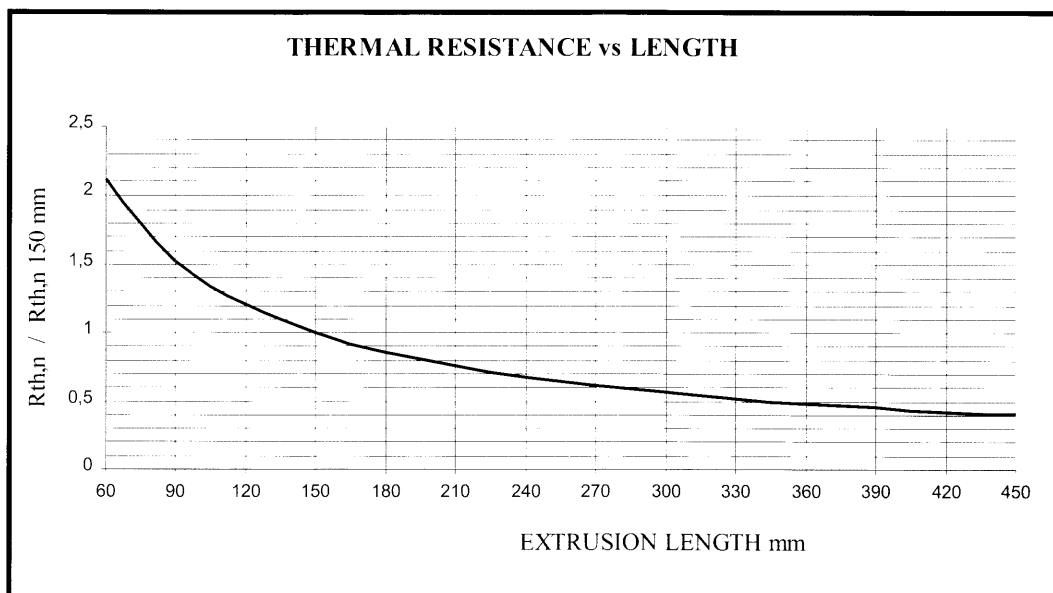

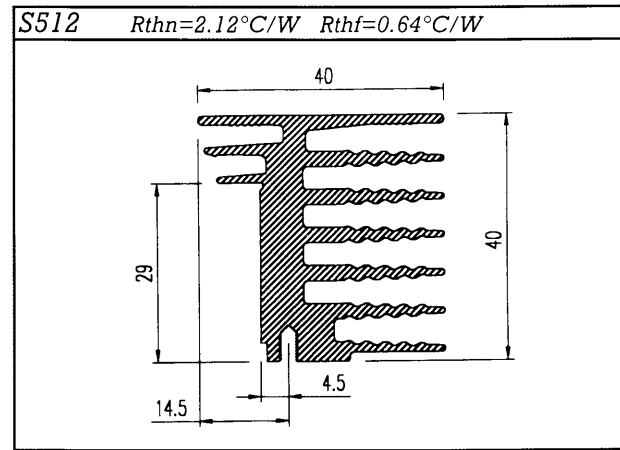
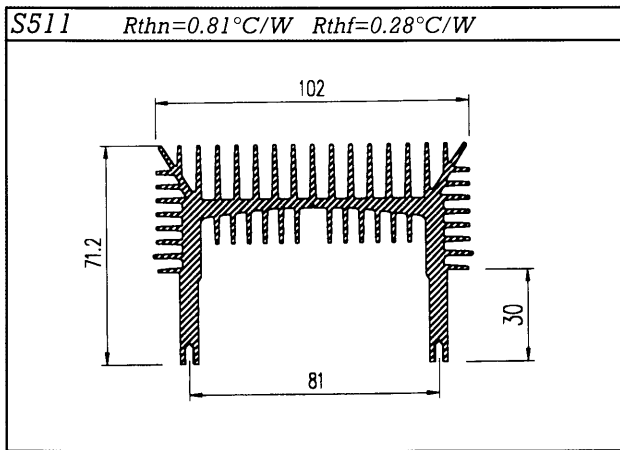
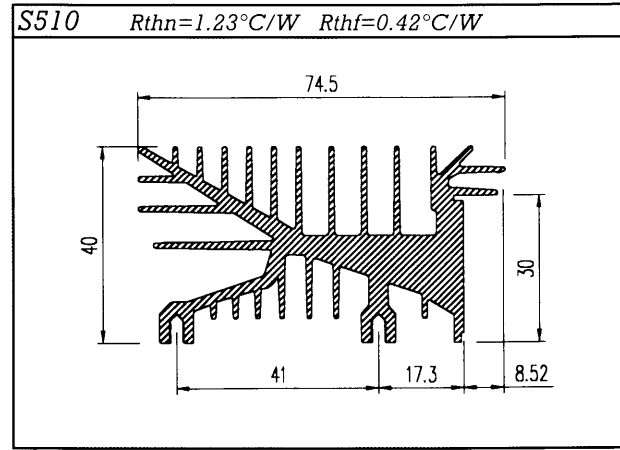
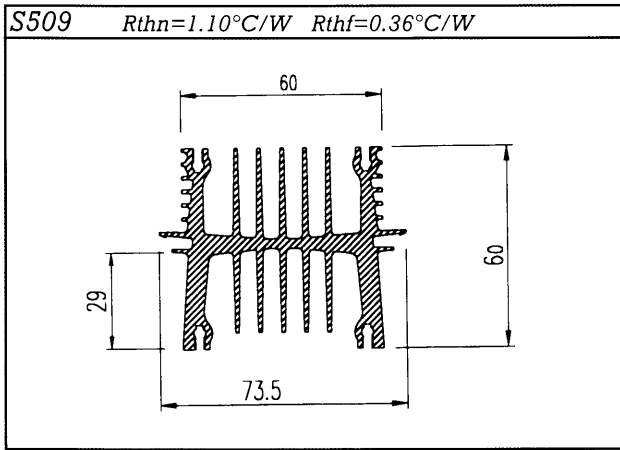
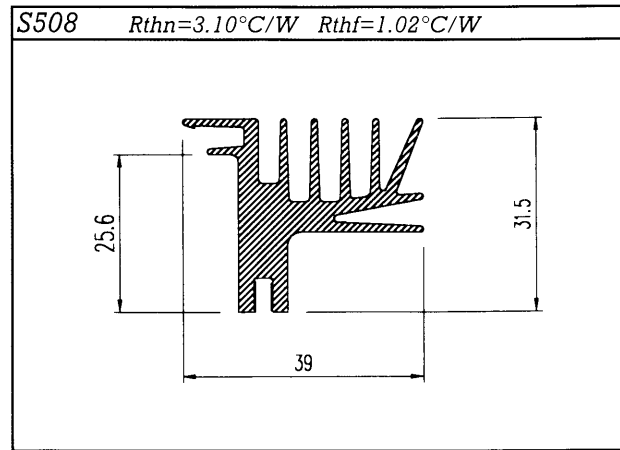
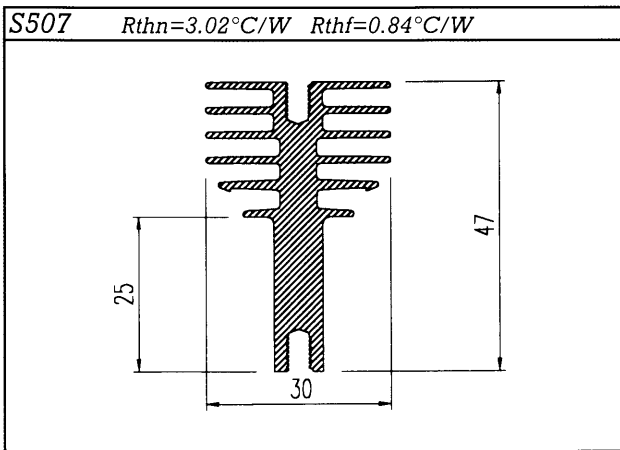
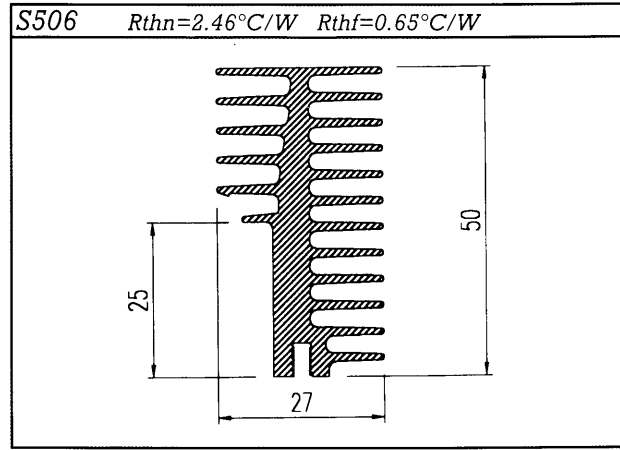
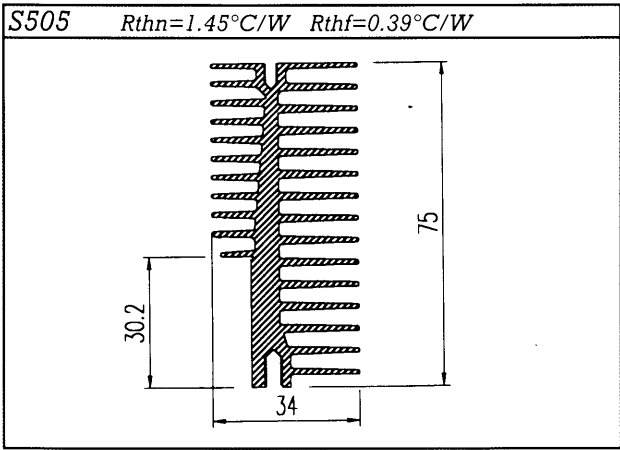

S515 (KM)  $R_{thn}=2.33^{\circ}\text{C/W}$   $R_{thf}=0.76^{\circ}\text{C/W}$

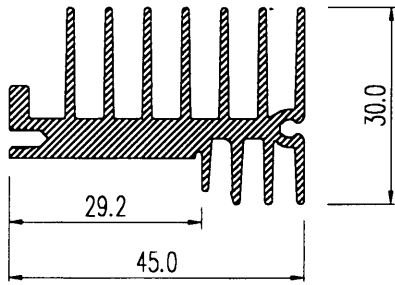

S517  $R_{thn}=1.55^{\circ}\text{C/W}$   $R_{thf}=0.41^{\circ}\text{C/W}$

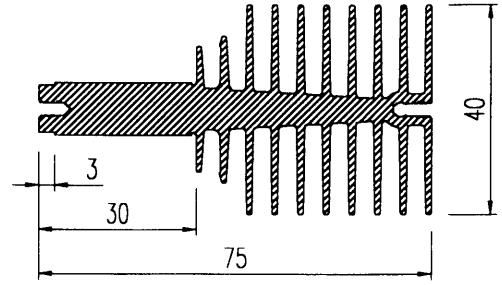

S518 (KR)  $R_{thn}=1.71^{\circ}\text{C/W}$   $R_{thf}=0.57^{\circ}\text{C/W}$

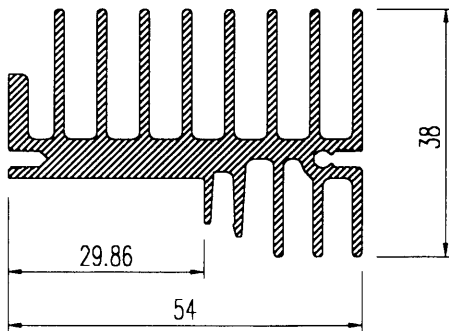

S520  $R_{thn}=2.49^{\circ}\text{C/W}$   $R_{thf}=0.74^{\circ}\text{C/W}$

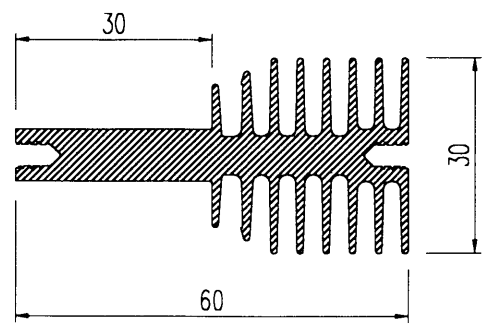

S521 Support Structure

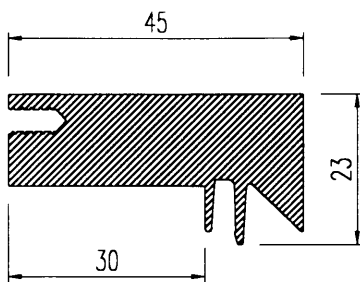

S522 Support Structure

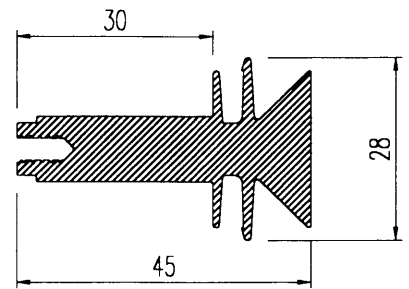

S526  $R_{thn}=2.30^{\circ}\text{C/W}$   $R_{thf}=0.42^{\circ}\text{C/W}$

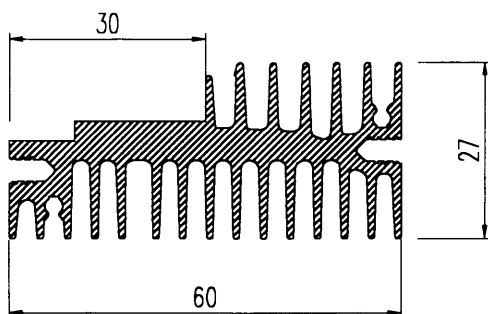

S527  $R_{thn}=1.64^{\circ}\text{C/W}$   $R_{thf}=0.33^{\circ}\text{C/W}$

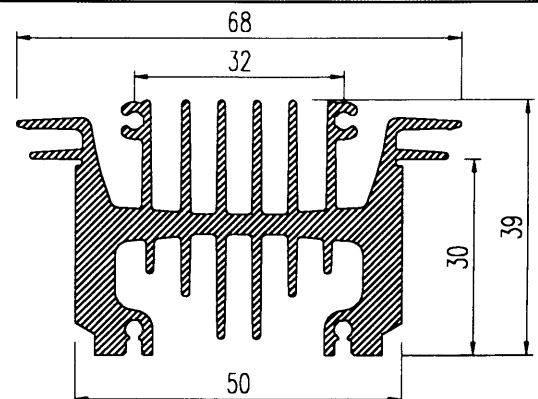

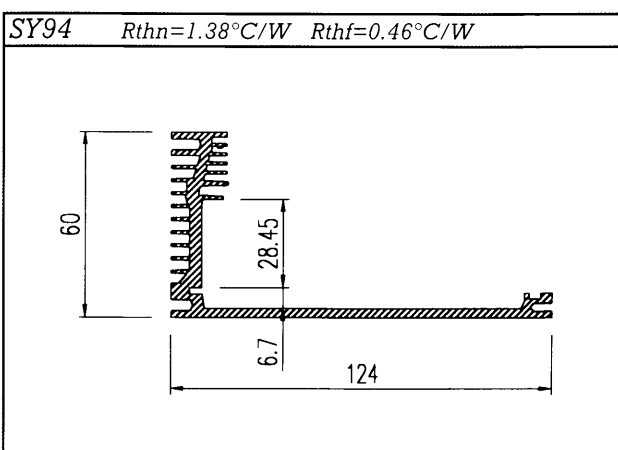
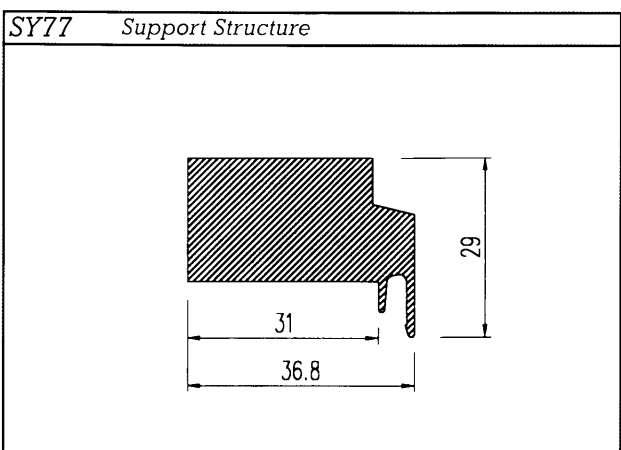
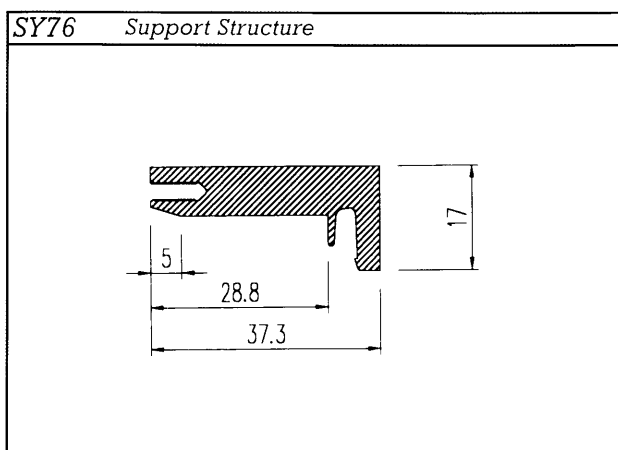
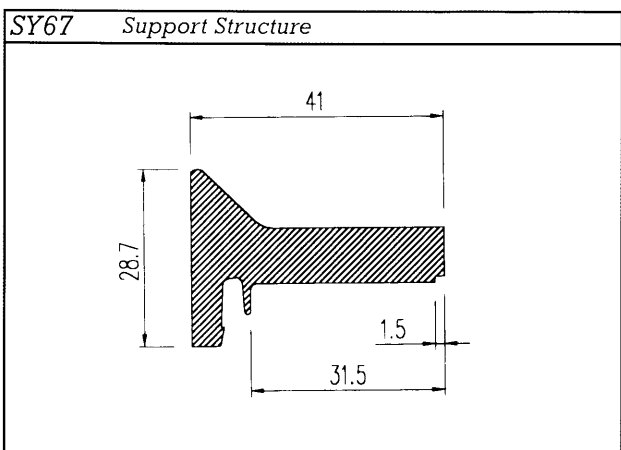
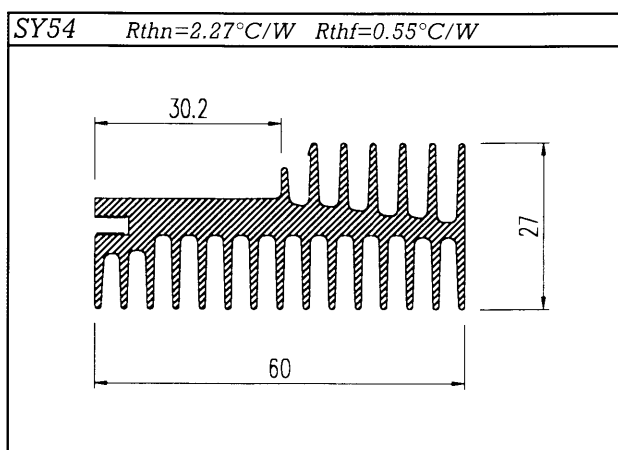
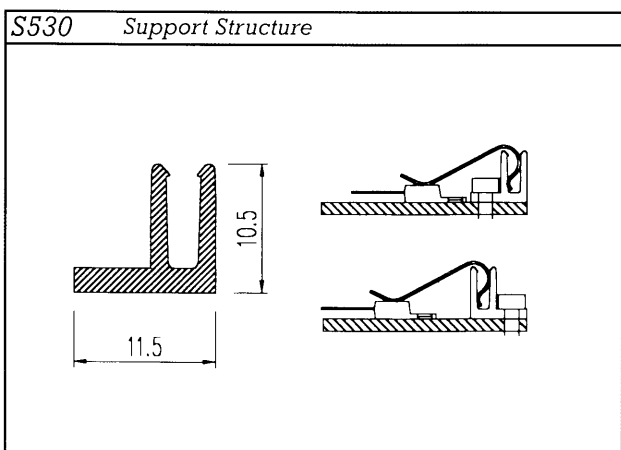
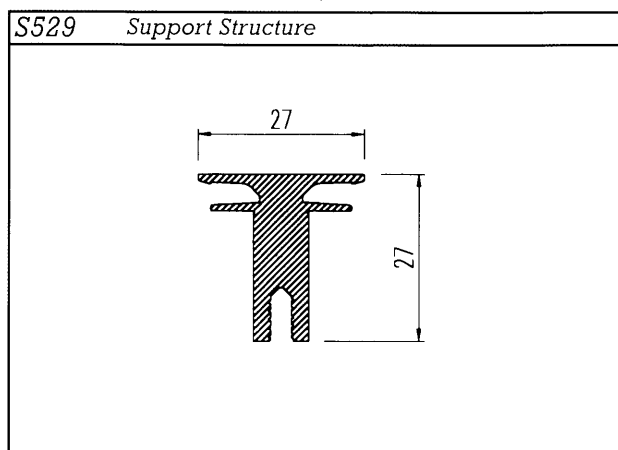
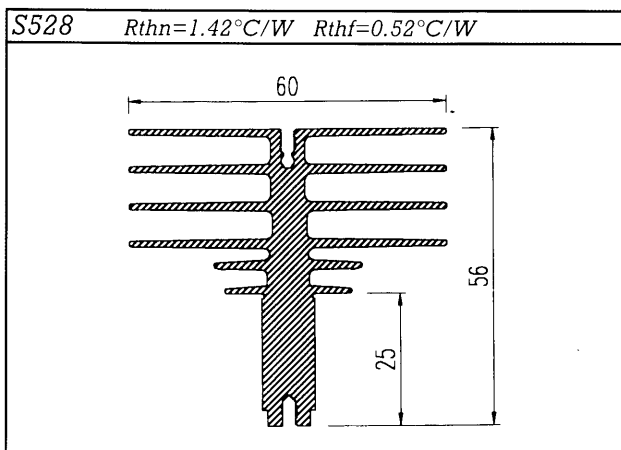



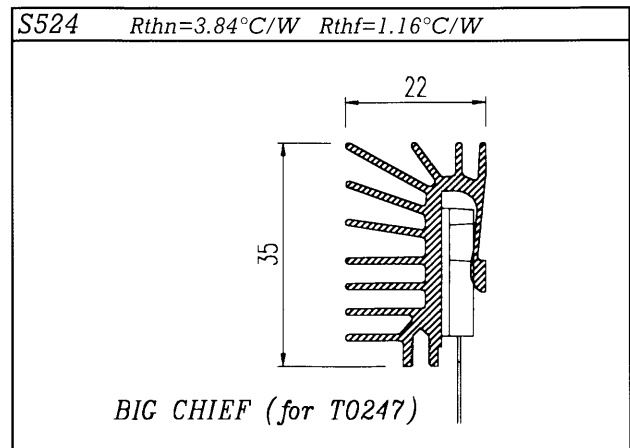
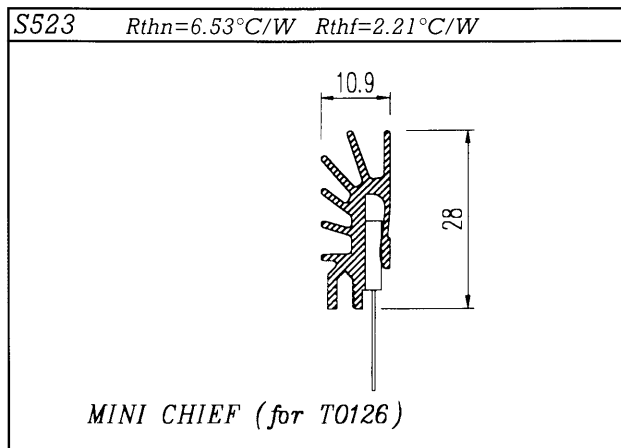
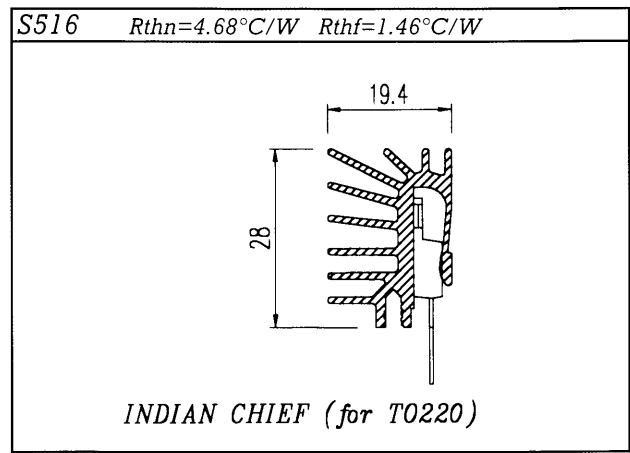
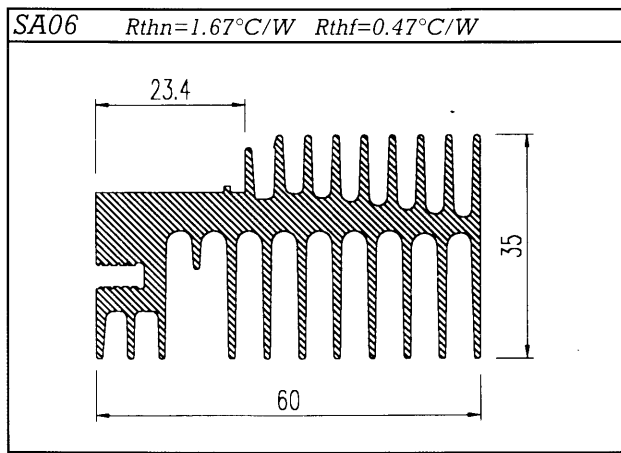

## The Indian Chief Family

The above extrusions S516, S523 & S524 are a brand new range of patented clip solutions from Thermalloy. Each incorporates an extruded clip and a very high surface area to weight ratio giving excellent thermal performance in natural and forced air environments. One or two transistors can be fitted to each customised length of extrusion.

## Solderable Pins

We now have available a range of solderable pins for the M3 and M4 slots in all of the extrusions in this brochure as well as for our standard range. These will be available with or without a standoff. We can provide automatic assembly of solderable pins to specified pitch and depth.

Yet another example of how Thermalloy is working to reduce your manufacturing time and cost. Please call us for more details.

*S509 with 60mm fan  $R_{th}=0.34^{\circ}\text{C}/\text{W}$*

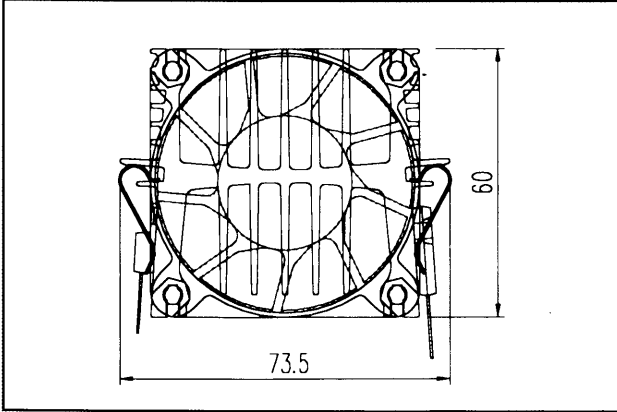

*SY54 x 8 with 119mm fan  $R_{th}=0.060^{\circ}\text{C}/\text{W}$*

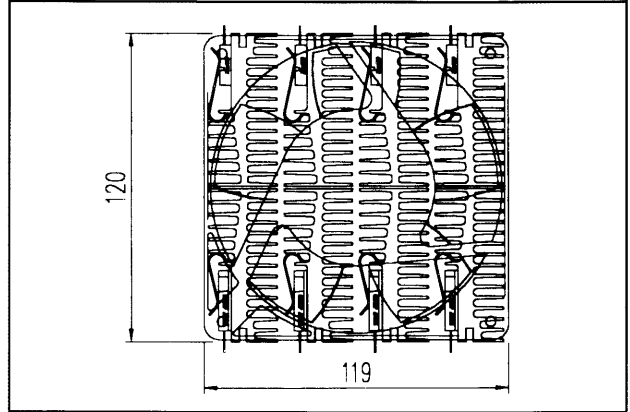

*SY67 as heatsink supports*

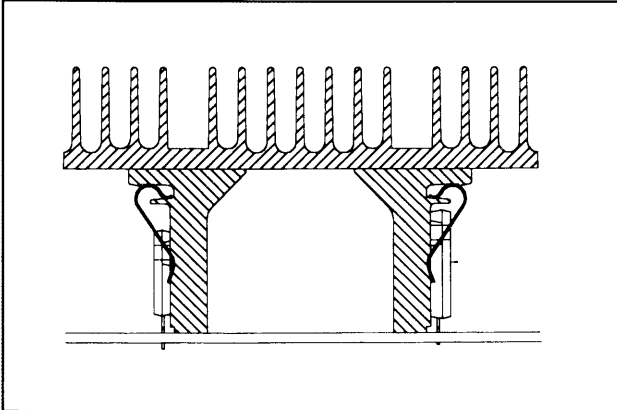

*S505 x 8 with 147mm fan  $R_{th}=0.038^{\circ}\text{C}/\text{W}$*

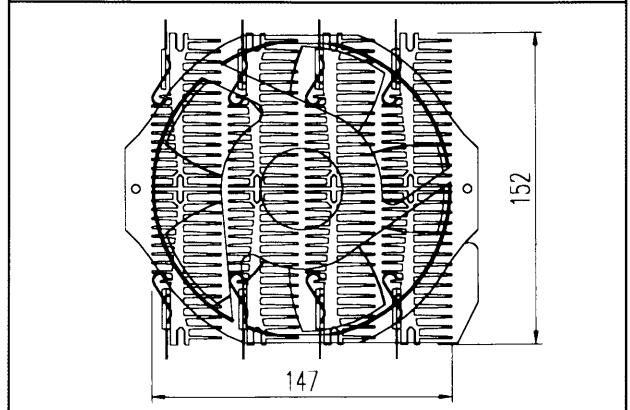

*Extrusions assembled using 212S*

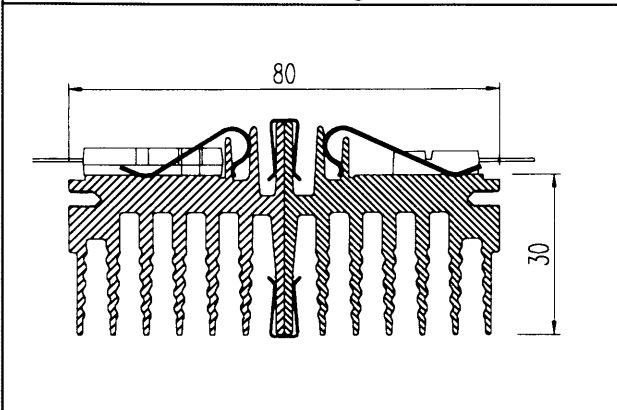

*S527 with 40mm fan  $R_{th}=0.45^{\circ}\text{C}/\text{W}$*

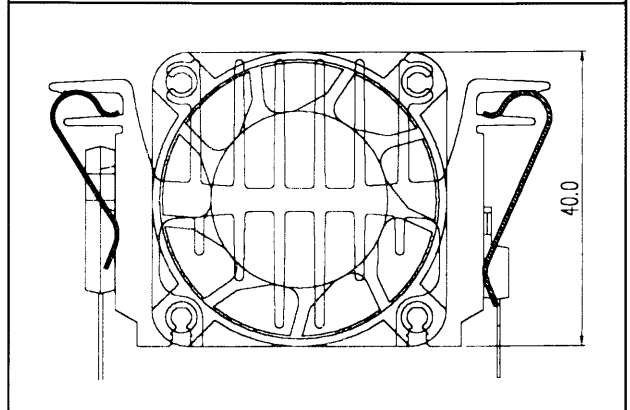

## **MAX CLIP SYSTEM Assembly Flexibility**

The above are examples of the flexible assembly possibilities of the MAX CLIP SYSTEM.

Several heatsink support types are available and some extrusions are designed to accept fans without modification.

Heatsinks can be assembled together using our proprietary clips so as to form a MULTIMAX assembly which can be fitted with a fan for enhanced thermal management capabilities.

Examples of MAX CLIP SYSTEM extrusions not yet tooled

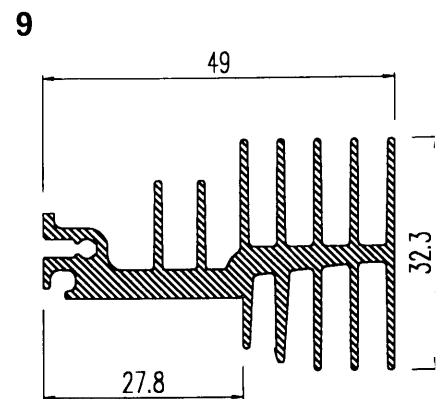
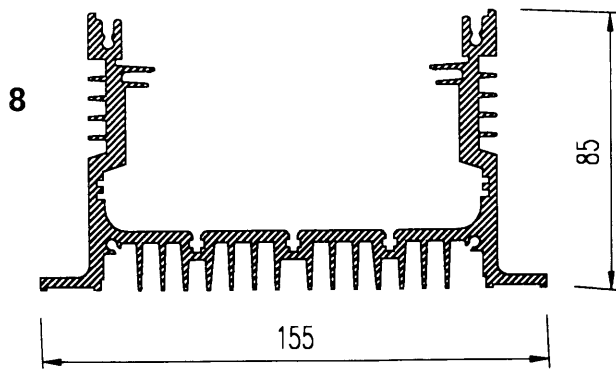
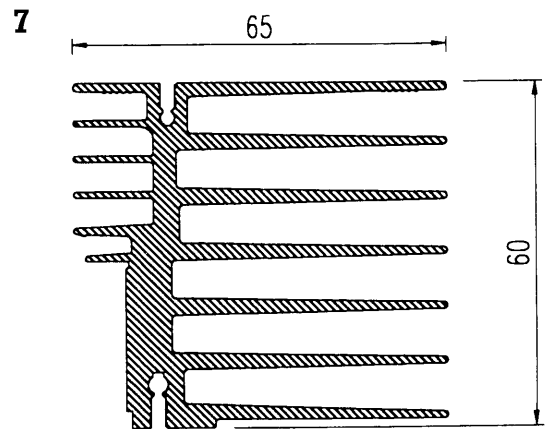
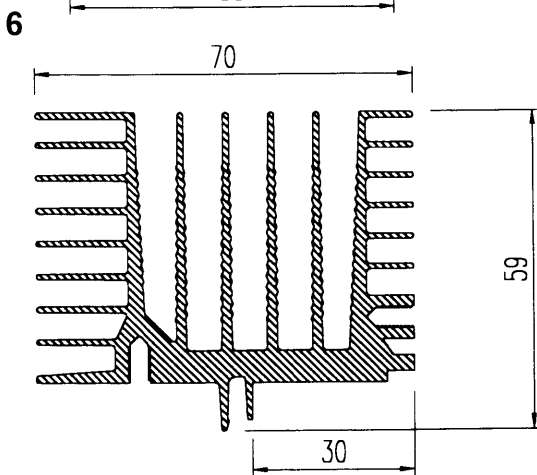
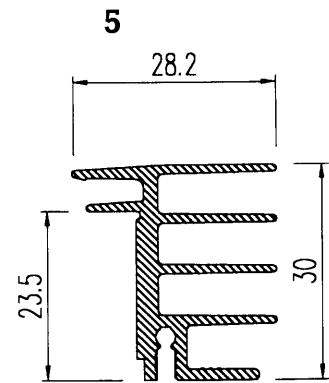
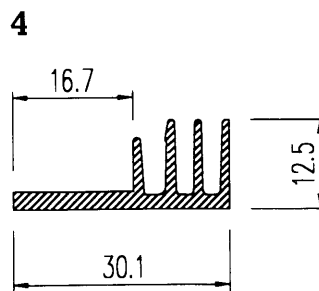
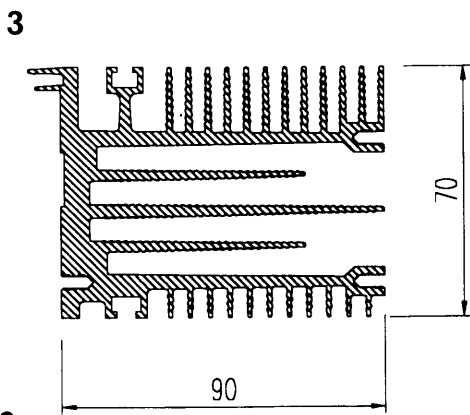
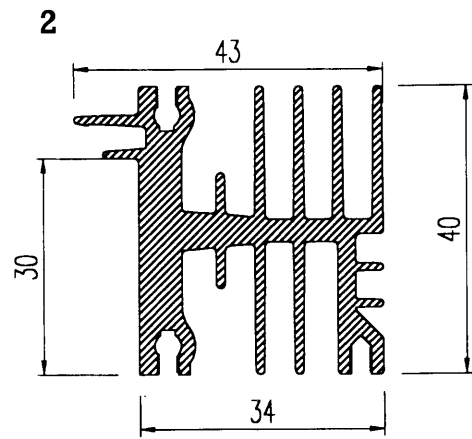
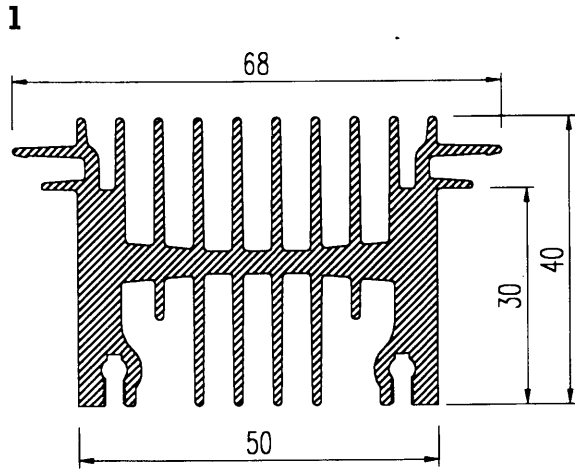

**CLIP SOLUTIONS ARE ONLY LIMITED BY THE IMAGINATION**

Clip Max01 = 10mm x 0.5 = 21 N

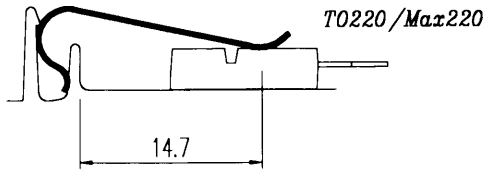

R500093

Clip Max02 = 12mm x 0.5 = 26 N

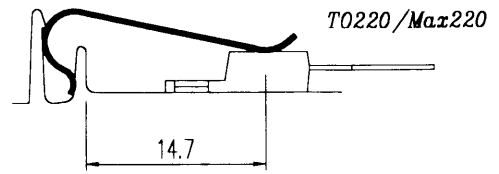

R500095

Clip Max03 = 15mm x 0.5 = 36 N

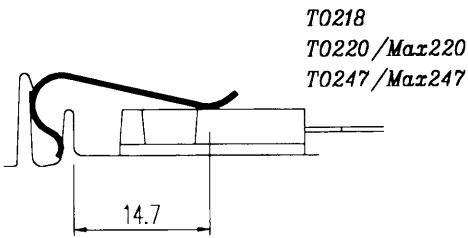

R500091

Clip Max04 = 20mm x 0.5 = 48 N

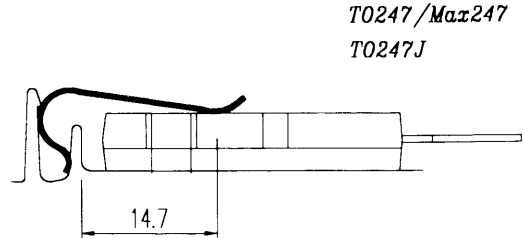

R500090

Clip Max07 = 12mm x 0.6 = 80 N

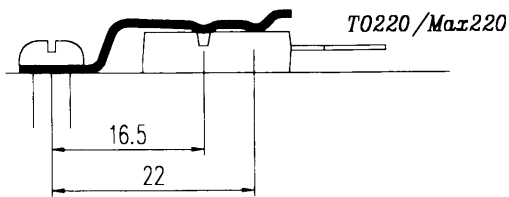

R500089

Clip Max08 = 18mm x 0.6 = 120 N

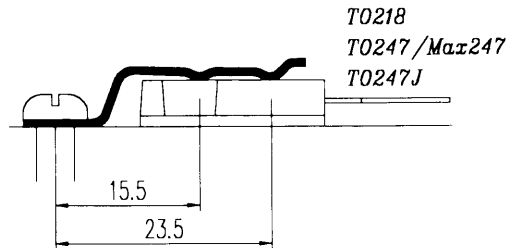

R500088

Clip Max09 = 10mm x 0.5 = 26 N

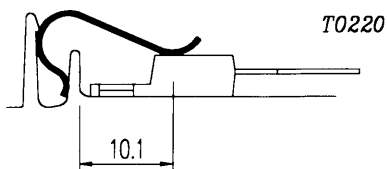

R500109

Clip Max10 = 12mm x 0.6 = 50 N

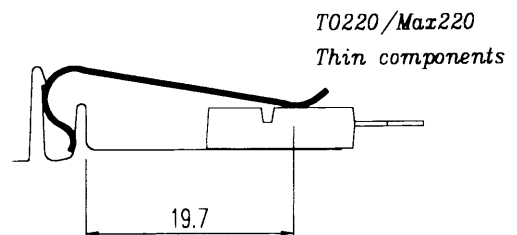

R500110

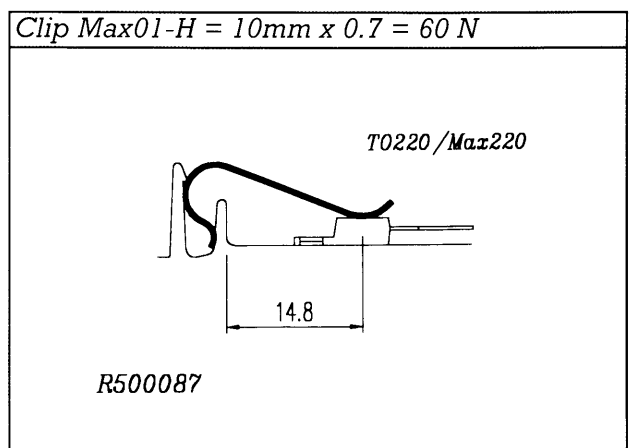
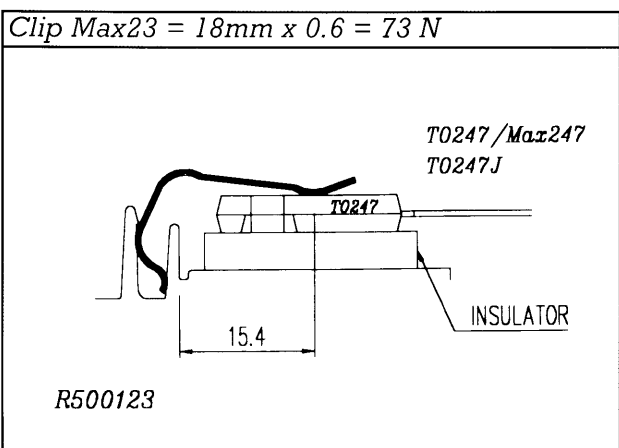
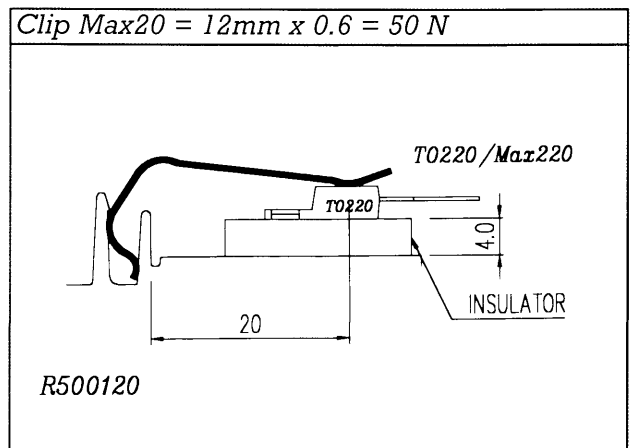
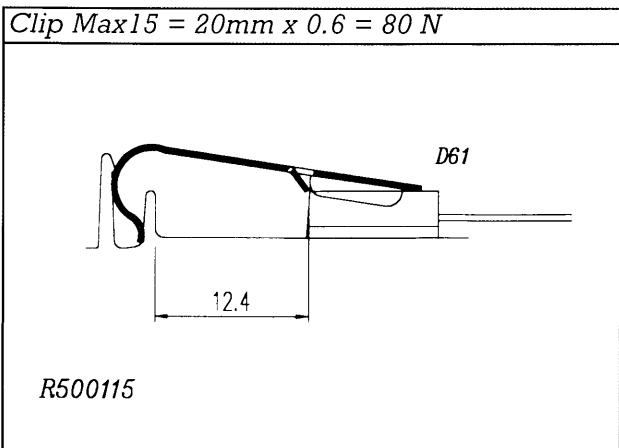
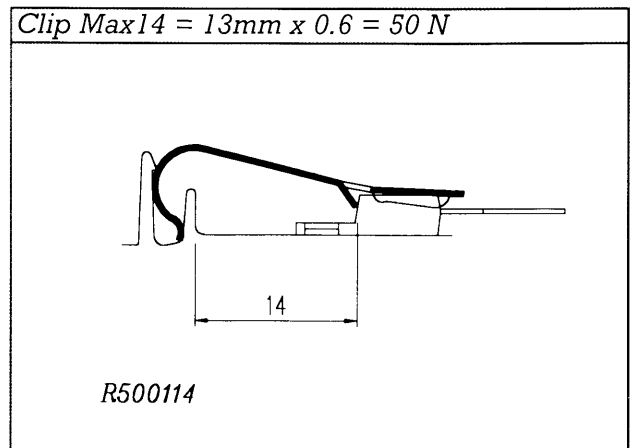
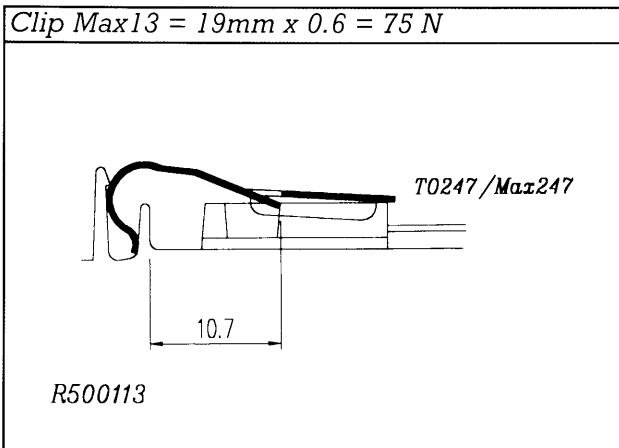
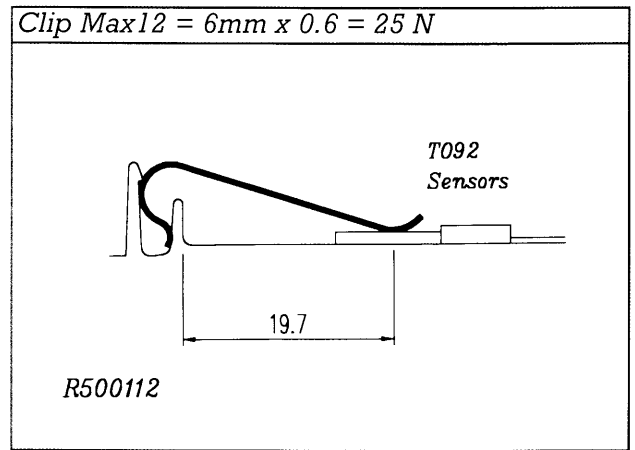
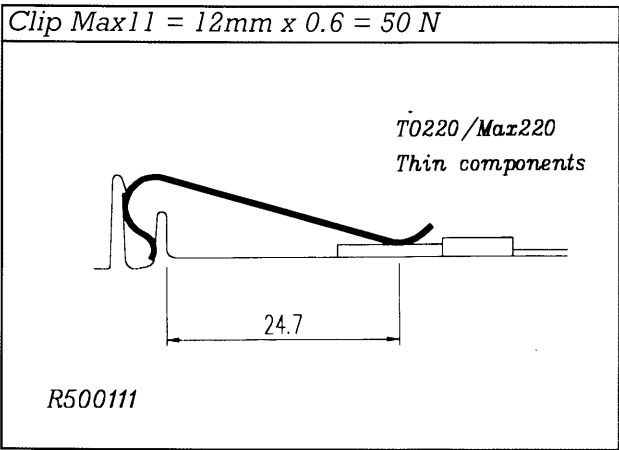

Clip Max02-H = 13mm x 0.6 = 50 N

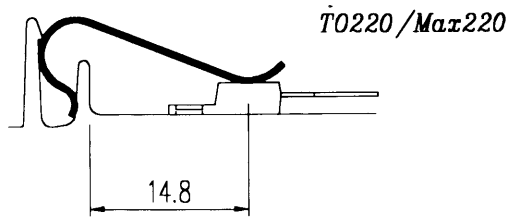

R500202

Clip Max03-H = 18mm x 0.6 = 73 N

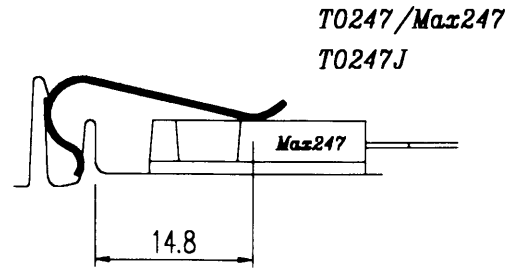

R500203

CLP212 = 10.1mm x 0.5 = 21 N

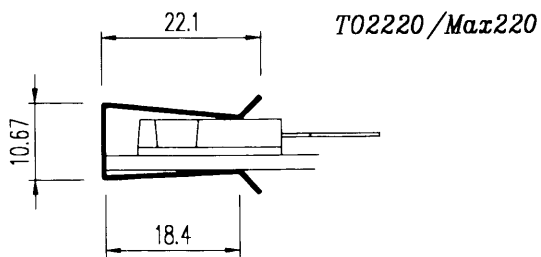

6230050

CLP212M = 15mm x 0.5 = 36 N

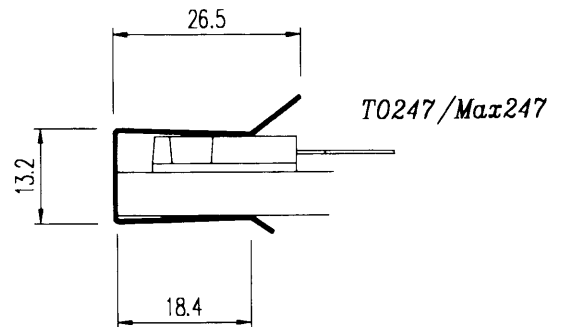

R500080

CLP212P = 10mm x 0.5 = 21 N

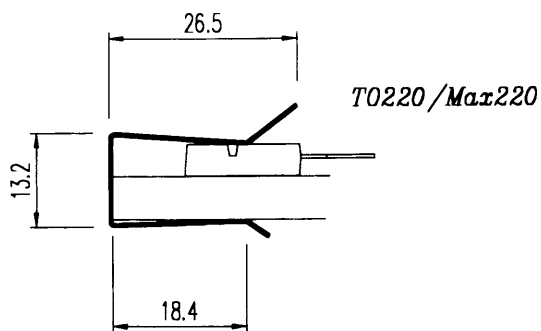

R500081

CLP212S = 7mm x 0.5 = 20 N

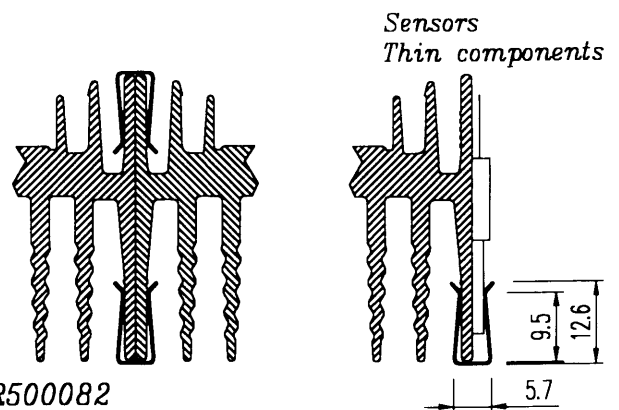

R500082